

REVISIONS			
REV.	DESCRIPTION	DATE	APPROVED
A	NEW DRAWING	10-27-11	GPD

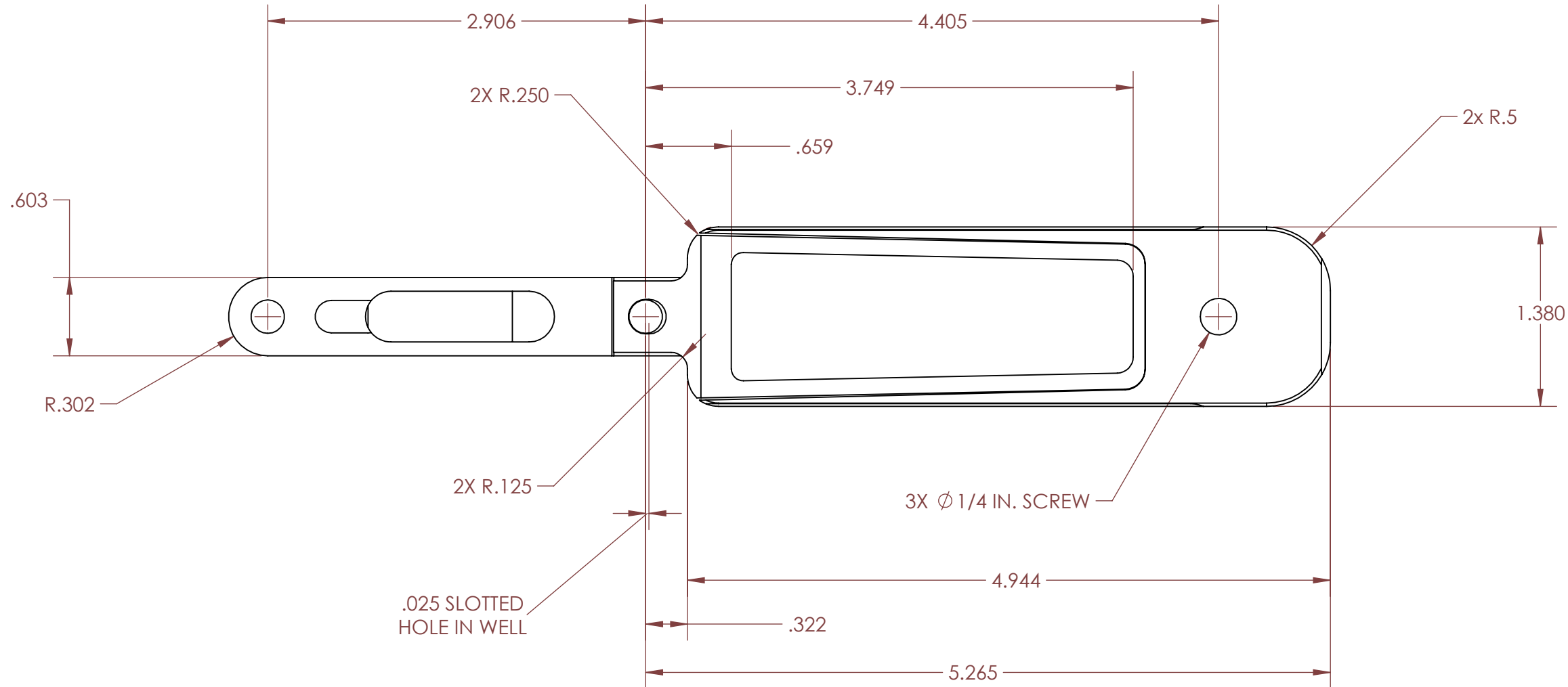

NOTES:

1. DIMENSIONS ARE TO NOMINAL BOTTOM METAL.
2. RECOMMENDED INLETING IF +.010 ALL AROUND.
3. DETERMINE DEPTH OF CUT BY TAKING ACTUAL DIMENSIONS OFF OF PARTS BEING INLET.

UNLESS OTHERWISE SPECIFIED:		NAME	DATE	B.M.L. Tool & Mfg. Corp.		
DIMENSIONS ARE IN INCHES TOLERANCES: FRACTIONAL ±1/32 ANGULAR: MACH ± .5° BEND ± 5° DRAFT: ± .25° TWO PLACE DECIMAL ±.02 THREE PLACE DECIMAL ±.005		DRAWN BY	GPD 10-27-11			
INTERPRET GEOMETRIC TOL. PER: ASME Y14.5M-1994		CHECKED		TITLE: INLETING: SHORT ACTION SAVAGE 110		
MATERIAL N/A		ENG APPR.				
FINISH SEE NOTES		MFG APPR.		SIZE	DWG. NO.	REV
FILE:		Q.A.		B	STD-104	A
		COMMENTS: DO NOT SCALE DRAWING		SCALE: 1:4	WEIGHT:	SHEET 1 OF 1

PROPRIETARY AND CONFIDENTIAL
THE INFORMATION CONTAINED IN THIS DRAWING IS THE SOLE PROPERTY OF **BML Tool & Mfg. Corp.** ANY REPRODUCTION IN PART OR AS A WHOLE WITHOUT THE WRITTEN PERMISSION OF **BML Tool & Mfg. Corp.** IS PROHIBITED.